

SMD Optocoupler with Phototransistor Output

Description

The TCMT1030 Series consist of a phototransistor optically coupled to a gallium arsenide infrared emitting diode in a 8 lead plastic dual inline packages.

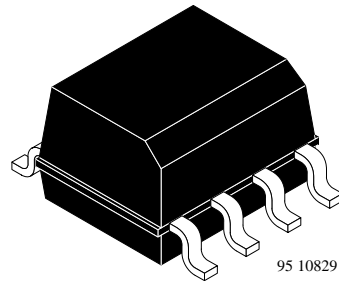

Applications

- Computer peripheral interface
- Microprocessor system interface
- Low power DC/DC converter
- Hybride substrates that require high density mounting

Features

- Current Transfer Ratio selected into 4 groups specified at $I_F = 1 \text{ mA}$
- Test isolation voltage between input and output $V_{IO} \text{ (RMS): } 2.5 \text{ kV}$
- 8 lead package, similar SOIC – 8
- Minimum $V_{(BR)CEO}$ of 90 V guaranteed
- Soldering methods according to CECC 00802 table 1, class B or C
- Low temperature coefficient of CTR
- Base connected
- Suitable for cleaning process without chemical solvent

Pin Connection

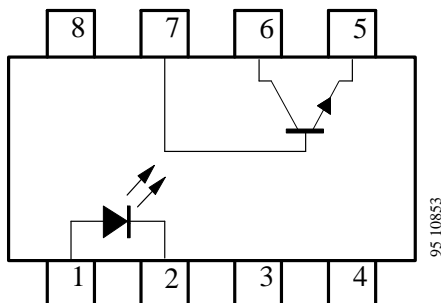

Absolute Maximum Ratings

Input (Emitter)

Parameters	Test Conditions	Symbol	Value	Unit
Reverse voltage		V_R	5	V
Forward current		I_F	60	mA
Forward surge current	$t_p \leq 10 \mu s$	I_{FSM}	3	A
Power dissipation	$T_{amb} \leq 25^\circ C$	P_{tot}	100	mW
Junction temperature		T_j	125	$^\circ C$

Output (Detector)

Parameters	Test Conditions	Symbol	Value	Unit
Collector base voltage		V_{CBO}	90	V
Collector emitter voltage		V_{CEO}	90	V
Emitter collector voltage		V_{ECO}	7	V
Collector current		I_C	50	mA
Collector peak current	$t_p/T = 0.5, t_p \leq 10 ms$	I_{CM}	100	mA
Power dissipation	$T_{amb} \leq 25^\circ C$	P_{tot}	150	mW
Junction temperature		T_j	125	$^\circ C$

Coupler

Parameters	Test Conditions	Symbol	Value	Unit
AC isolation test voltage (RMS)		V_{IO}	2.5	kV
Total power dissipation	$T_{amb} \leq 25^\circ C$	P_{tot}	250	mW
Ambient temperature range		T_{amb}	-55 to +100	$^\circ C$
Storage temperature range		T_{stg}	-55 to +125	$^\circ C$
Soldering classification	single wave, $t \leq 10 s$	T_{sd}	260	$^\circ C$

1) related standard climate 23/50 DIN 50014

Electrical Characteristics

Input (Emitter)

Parameters	Test Conditions	Symbol	Min.	Typ.	Max.	Unit
Forward voltage	$I_F = 50 \text{ mA}$	V_F		1.25	1.6	V
Breakdown voltage	$I_R = 100 \text{ } \mu\text{A}$	$V_{(BR)}$	5			V
Junction capacitance	$V_R = 0, f = 1 \text{ MHz}$	C_j		50		pF

Output (Detector)

Parameters	Test Conditions	Symbol	Min.	Typ.	Max.	Unit
Collector base breakdown voltage	$I_C = 100 \text{ } \mu\text{A}$	$V_{(BR)C80}$	90			V
Emitter collector breakdown voltage	$I_C = 1 \text{ mA}$	$V_{(BR)CEO}$	90			V
Emitter collector breakdown voltage	$I_E = 100 \text{ } \mu\text{A}$	$V_{(BR)ECO}$	7			V
Collector emitter cut-off current	$V_{CE} = 10 \text{ V}, I_f = 0, E = 0$	I_{CEO}			50	nA

Coupler

Parameters	Test Conditions	Symbol	Min.	Typ.	Max.	Unit
AC isolation test voltage (RMS)	$f = 50 \text{ Hz}, t = 1 \text{ s}$	V_{IO}	2.5			kV
Collector emitter saturation voltage	$I_F = 10 \text{ mA}, I_C = 1 \text{ mA}$	V_{CEsat}			0.3	V
Cut-off frequency	$I_F = 10 \text{ mA}, V_{CE} = 5 \text{ V}, R_L = 100 \text{ } \Omega$	f_C		110		kHz
Coupling capacitance	$f = 1 \text{ MHz}$	C_k		0.3		pF

Current Transfer Ratio (CTR)

Parameters	Test Conditions	Type	Symbol	Min.	Typ.	Max.	Unit
I_C/I_F	$V_{CE} = 5 \text{ V}, I_F = 1 \text{ mA}$	TCMT1030	CTR	0.1			
		TCMT1031	CTR	0.2	0.5		
		TCMT1032	CTR	0.5	1		
		TCMT1033	CTR	1	2		
		TCMT1034	CTR	2	2.5		

TCMT1030 Series

TEMIC

TELEFUNKEN Semiconductors

Dimensions in mm

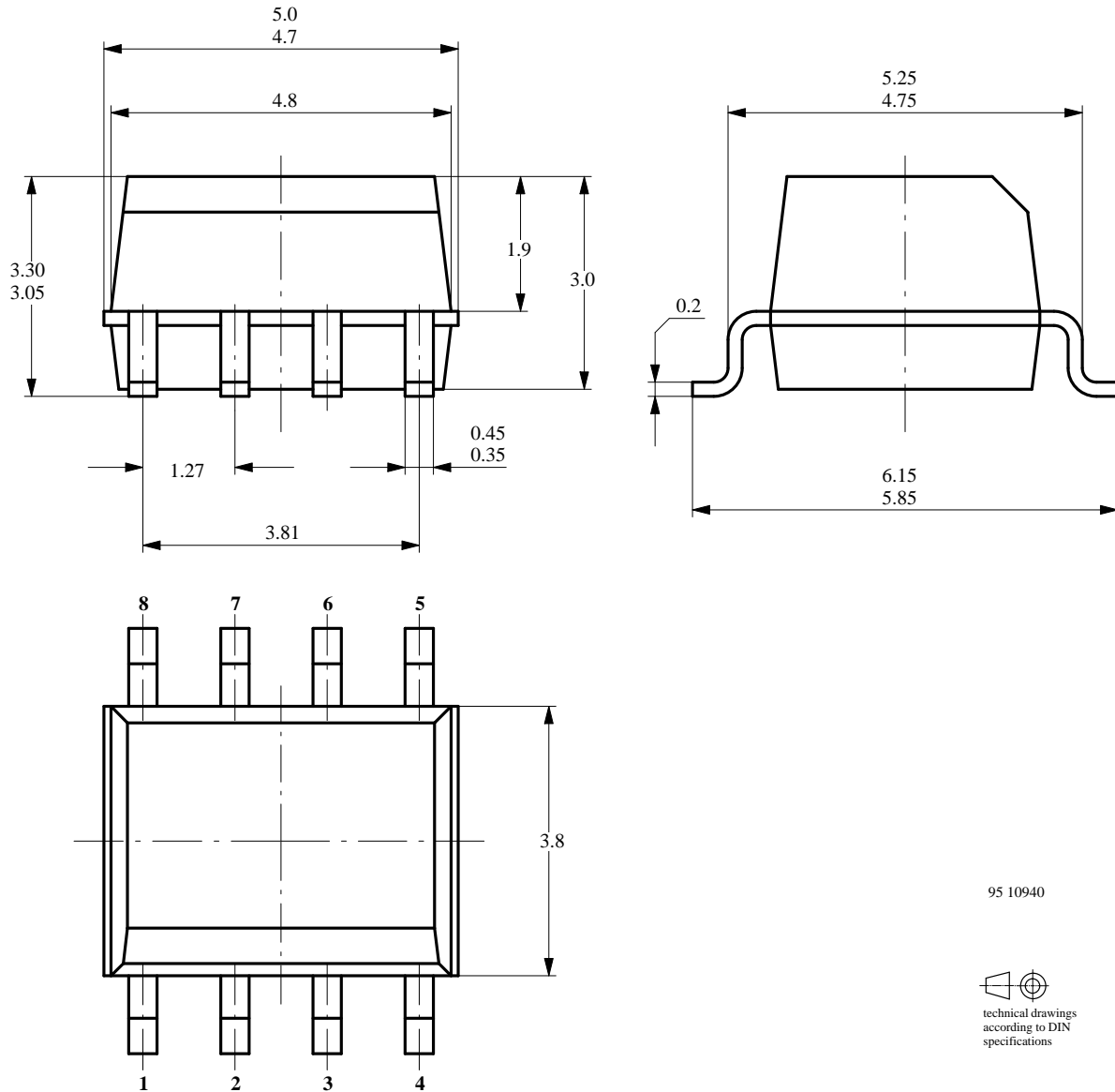

95 10940

technical drawings
according to DIN
specifications

Ozone Depleting Substances Policy Statement

It is the policy of **TEMIC TELEFUNKEN microelectronic GmbH** to

1. Meet all present and future national and international statutory requirements.
2. Regularly and continuously improve the performance of our products, processes, distribution and operating systems with respect to their impact on the health and safety of our employees and the public, as well as their impact on the environment.

It is particular concern to control or eliminate releases of those substances into the atmosphere which are known as ozone depleting substances (ODSs).

The Montreal Protocol (1987) and its London Amendments (1990) intend to severely restrict the use of ODSs and forbid their use within the next ten years. Various national and international initiatives are pressing for an earlier ban on these substances.

TEMIC TELEFUNKEN microelectronic GmbH semiconductor division has been able to use its policy of continuous improvements to eliminate the use of ODSs listed in the following documents.

1. Annex A, B and list of transitional substances of the Montreal Protocol and the London Amendments respectively
2. Class I and II ozone depleting substances in the Clean Air Act Amendments of 1990 by the Environmental Protection Agency (EPA) in the USA
3. Council Decision 88/540/EEC and 91/690/EEC Annex A, B and C (transitional substances) respectively.

TEMIC can certify that our semiconductors are not manufactured with ozone depleting substances and do not contain such substances.

We reserve the right to make changes to improve technical design and may do so without further notice.

Parameters can vary in different applications. All operating parameters must be validated for each customer application by the customer. Should the buyer use TEMIC products for any unintended or unauthorized application, the buyer shall indemnify TEMIC against all claims, costs, damages, and expenses, arising out of, directly or indirectly, any claim of personal damage, injury or death associated with such unintended or unauthorized use.

TEMIC TELEFUNKEN microelectronic GmbH, P.O.B. 3535, D-74025 Heilbronn, Germany
Telephone: 49 (0)7131 67 2831, Fax number: 49 (0)7131 67 2423